

Sprosse og stilsprosser ses på tegning NATic\_01\_3 - Udadgående vinduer og fast karm - 3-lags rude.  
 Glazing bar and styling bar can be seen at drawing NATic\_01\_3 - Outward opening windows and fixed light - 3-layer panes.

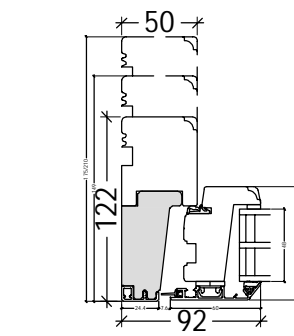

V1: NATic20-30L48  
 V7: NATic20-30L48(mirr.)

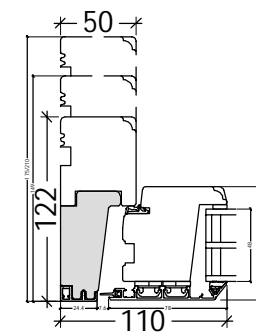

V1: NATic20-31L48  
 V7: NATic20-31L48 (mirr.)

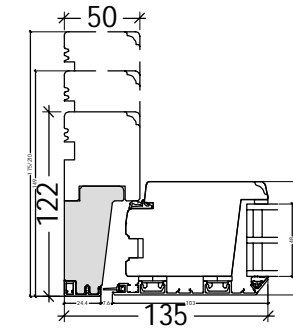

V1: NATic21-30L48  
 V7: NATic21-30L48(mirr.)

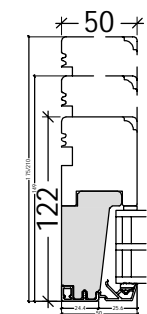

V4: FRAic21-31L48 (mirr.)  
 V5: FRAic21-31L48

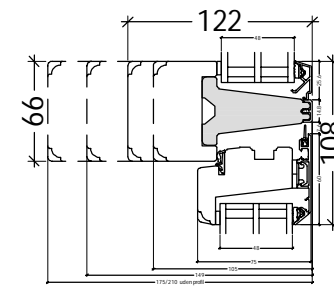

L6: NATic20-40L48  
 L5: NATic20-40L48 (mirr.)

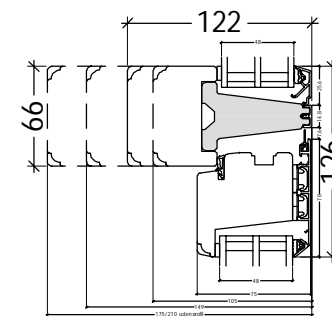

L6: NATic20-41L48

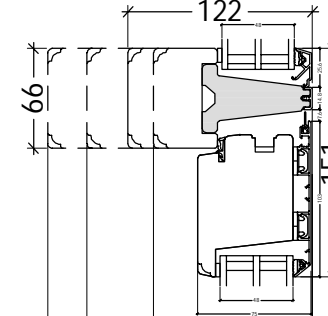

L6: NATic21-40L48

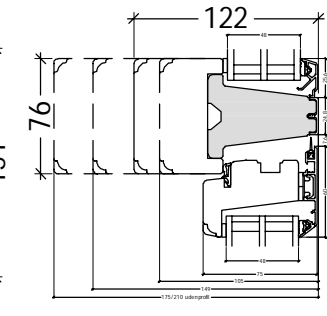

L6: NATic20-42L48  
 L5: NATic20-42L48 (mirr.)

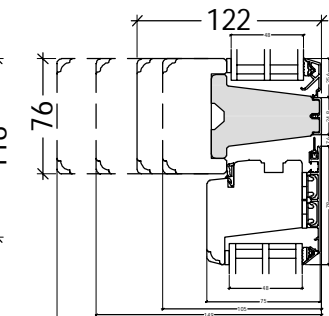

L6: NATic20-43L48

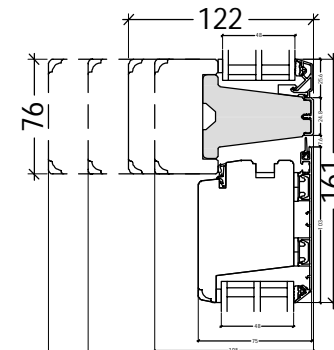

L6: NATic21-41L48

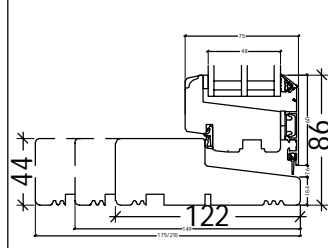

L2: NATic20-10L48

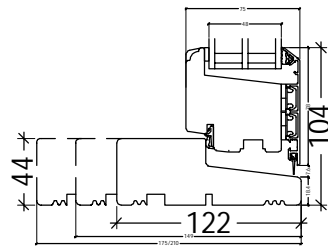

L2: NATic20-11L48

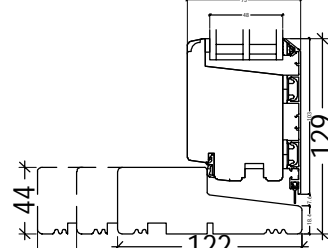

L2: NATic21-10L48

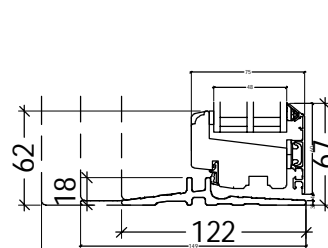

L2: NATic20-13L48

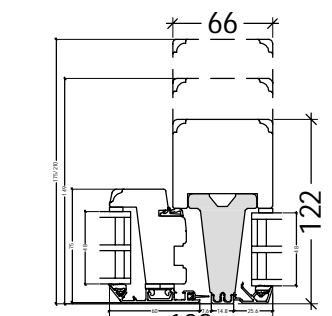

V6: NATic20-50L48 (mirr.)

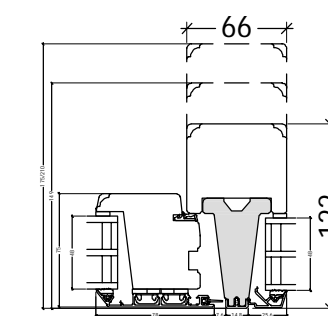

V6: NATic20-51L48 (mirr.)

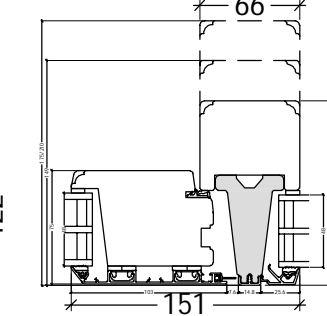

V6: NATic20-54L48 (mirr.)

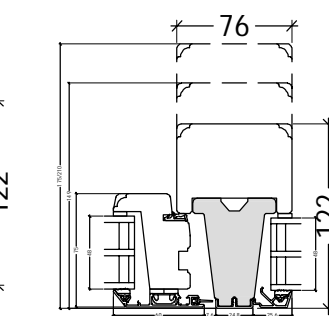

V3: NATic20-52L48  
 V6: NATic20-52L48(mirr.)

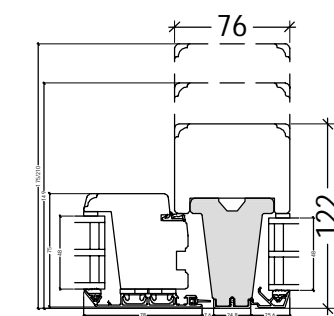

V3: NATic20-53L48  
 V6: NATic20-53L48(mirr.)

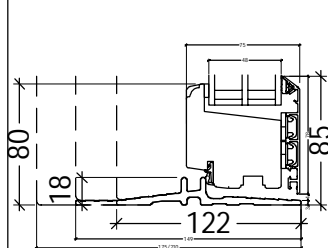

L2: NATic20-14L48

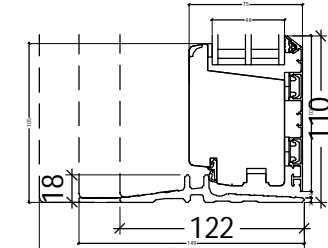

L2: NATic21-15L48

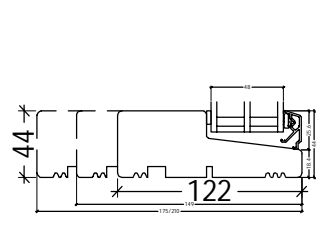

L4: FRAic20-12L48

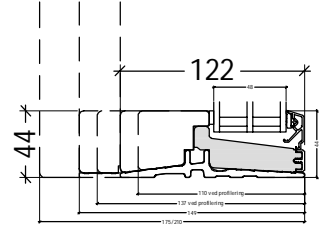

L4: FRAic20-15L48

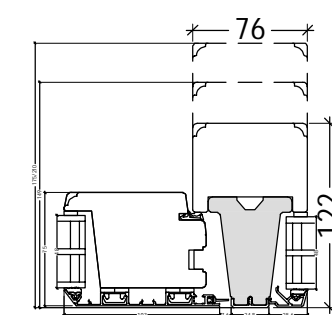

V3: NATic21-50L48  
 V6: NATic21-50L48(mirr.)

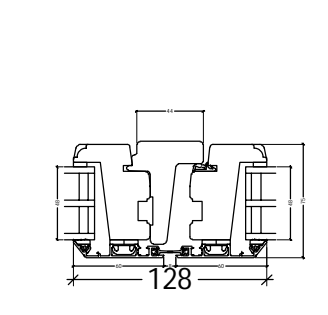

V2: NATic20-80L48

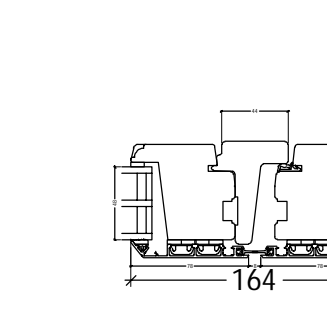

V2: NATic20-81L48

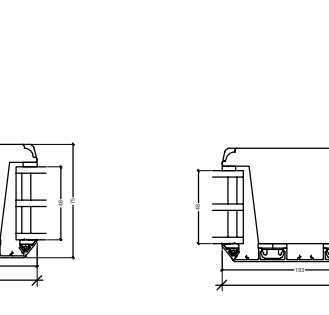

V2: NATic20-82L48

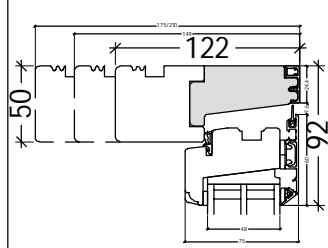

L1: NATic01-20L48

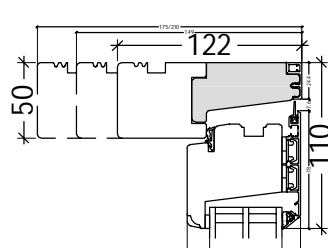

L1: NATic20-21L48

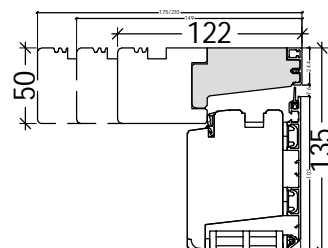

L1: NATic21-20L48

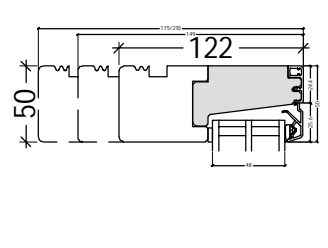

L3: FRAic06-20L48

DK	Udadgående terrassedør - 3-lags rude	www.idealcombi.dk
UK	Outward opening terrace door - 3-layer panes	