

Stilsprosser ses på tegning PLU_01_3 - Udadgående vinduer og fast karm - 3-lags rude.
 Styling bar can be seen at drawing PLU_01_3 - Outward opening windows and fixed light - 3-layer panes.

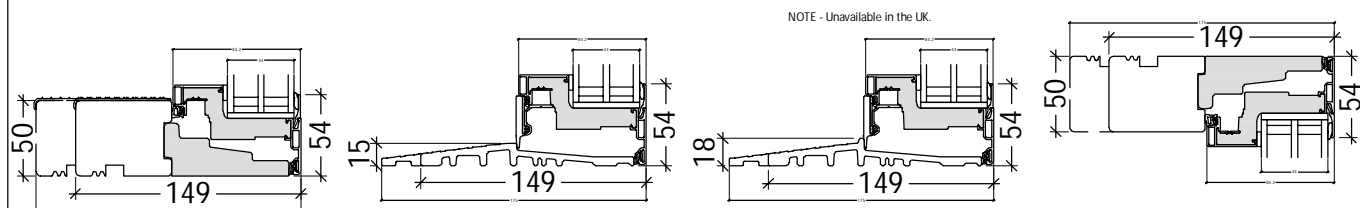

NOTE - Unavailable in the UK

L2: PLU20-10L44

L2: PLU20-11L44

L2: PLU20-12L44

L1: PLU20-20L44

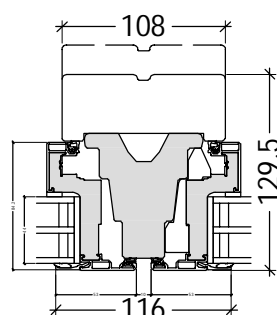
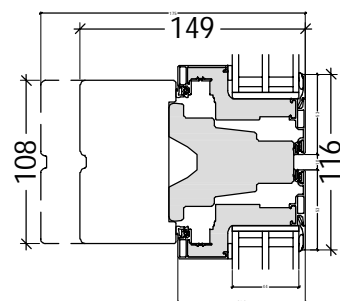
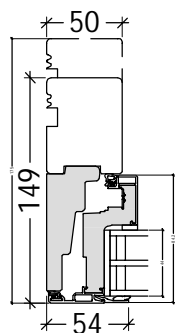

V1/V4: PLU20-30L44

V3/V5: PLU20-30L44(mirr.)

L3: PLU20-40L44

V2: PLU20-50L44

DK Udadgående terrassedør - 3-lags rude

www.idealcombi.dk

UK Outward opening terrace door - 3-layer panes

www.idealcombi.com

TYPE

Futura+

Rev. no. 01

Drawing no. PLU_20_3

© Idealcombi A/S 2011. This material is the property of and copyright protected by IDEALCOMBI A/S.

idealcombi
Udvikler vinduet